

# PH380 series Solar Pump Inverter

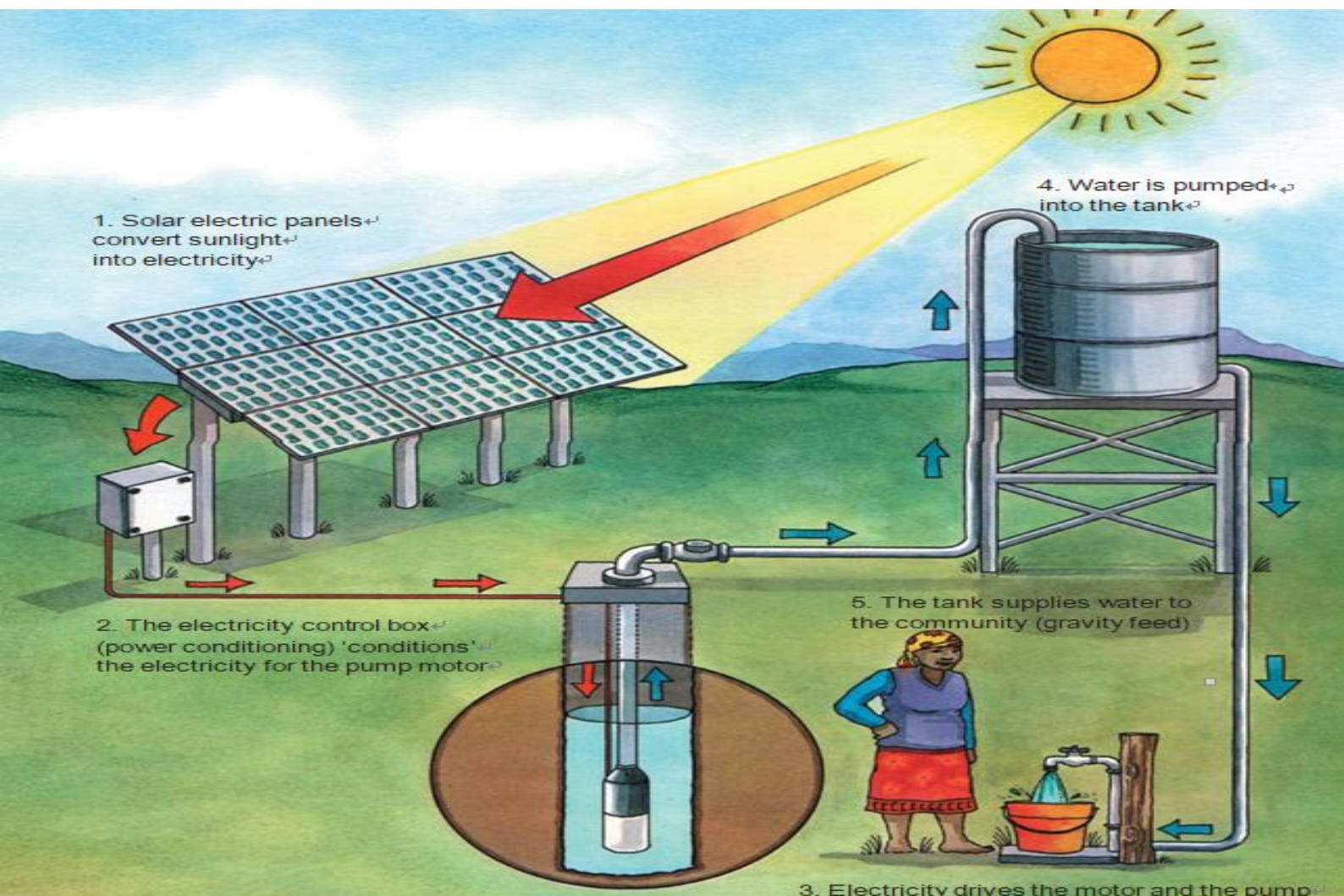

Always deliver more than expected!



## Solar Pump System Diagram

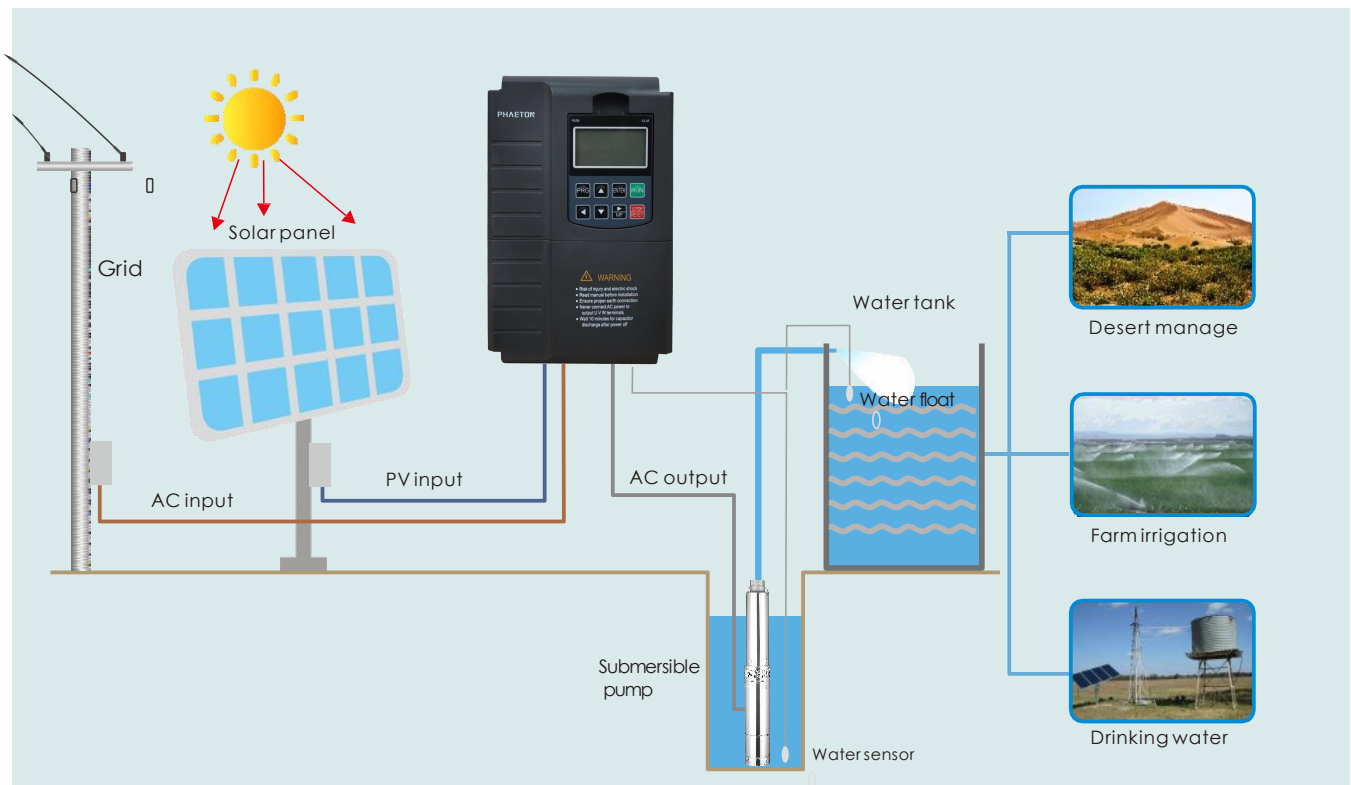

## Solar Pump Inverter Features

- Maximum power point tracking (MPPT) with fast response speed and stable operation efficiency > 99%
- Suits for most 3 phase AC pumps and AC PMSM high efficiency pumps
- Compatible with AC grid and DC power supply input at same time
- Built in automatic sleep-wake up function
- Dry run (under load ) protection
- Motor maximum current protection
- Low input power protection
- Lowest stop frequency protection
- The PQ (power/flow) performance curve enables calculating the flow output from the pump
- Digital control for fully automatic operation, data storage and protective functions
- Low water probe sensor, and water level control function
- Strong lightning protection
- Ambient temperature for using: -10 to +50°C
- Clock relay card for timing stop and stop control
- LCD keypad as optional
- Input VOC auto-detect function

# Product Datasheet & technical specification&Diagram

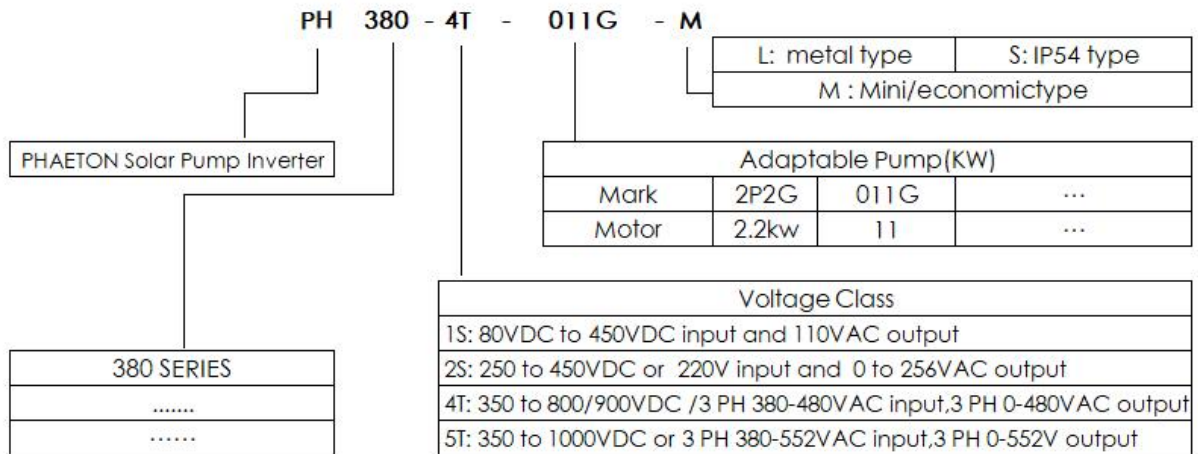

**PH380-XX-M**



1.5-2.2KW

**PH380-XX-S**



1.5-2.2KW

**PH380-XX-L**



1.5-7.5KW

**PH380**



1.5-560KW

Model	Applicable for pumps	Input DC voltage	Over voltage point	Under voltage point	Suggest Vmp	Suggest Voc
PH380-2S	For 220V AC	150V – 450V	450V	100V	310VDC	380VDC
PH380-4T	For 380V/480V AC	350V – 900V	800V/900V	200V	520VDC	650VDC

## Datasheet

SN	Model No.	Rate current	Output voltage	Applicable for pumps	External of drive size(mm)H*W*D	MPPT voltage (VDC)	Weight (kg)
<b>PH380-XX-M mini model 2S series: Input 150-450V DC or 200 to 240V AC, VOC 350V DC</b>							
1	PH380-2S-1P5G-M	7A	0-256VAC	1.5KW	151*100*127	260 to 375	1.4
2	PH380-2S-2P2G-M	10A	0-256VAC	2.2KW	151*100*127	260 to 375	1.4
<b>PH380-XX-M mid model 4T series: Input 350 to 800V/900VDC or 380 to 480V AC, VOC 620VDC</b>							
1	PH380-4T-1P5G-M	3.7A	0-480VAC	1.5KW	151*100*127	486 to 750	1.4
2	PH380-4T-2P2G-M	5A	0-480VAC	2.2KW	151*100*127	486 to 750	1.4

PH380 standard model 2S series : Input 150 to 450V DC or 200 to 240V AC, VOC 350 VDC							
1	PH380-2S-1P5G	7A	0-256VAC	1.5KW	185*118*153.8	260 to 375	2
2	PH380-2S-2P2G	10A	0-256VAC	2.2KW	185*118*153.8	260 to 375	2.5
3	PH380-2S-004G	16A	0-256VAC	4.0KW	247*160*175	260 to 375	4.3
PH380 standard model 4T series : Input 350 to 800V/900VDC or 380 to 480V AC, VOC 620V DC							
1	PH380-4T-2P2G	5A	0-480VAC	2.2KW	185*118*153.8	486 to 750	3
2	PH380-4T-004G	10A	0-480VAC	4KW	185*118*153.8	486 to 750	3
3	PH380-4T-5P5G	13A	0-480VAC	5.5KW	247*160*175	486 to 750	4.2
4	PH380-4T-7P5G	17A	0-480VAC	7.5KW	247*160*175	486 to 750	4.3
5	PH380-4T-011G	25A	0-480VAC	11KW	247*160*175	486 to 750	4.5
6	PH380-4T-015G	30A	0-480VAC	15KW	320*220*197.3	486 to 750	7.3
7	PH380-4T-018G	37A	0-480VAC	18KW	320*220*197.3	486 to 750	7.5
8	PH380-4T-022G	45A	0-480VAC	22KW	415*230*205	486 to 750	12
9	PH380-4T-030G	60A	0-480VAC	30KW	480*260*215	486 to 750	17
10	PH380-4T-037G	75A	0-480VAC	37KW	480*260*215	486 to 750	17.5
11	PH380-4T-045G	91A	0-480VAC	45KW	575*320*310	486 to 750	35
12	PH380-4T-055G	110A	0-480VAC	55KW	575*320*310	486 to 750	36
13	PH380-4T-075G	150A	0-480VAC	75KW	620*380*310	486 to 750	45
14	PH380-4T-093G	180A	0-480VAC	93KW	620*380*310	486 to 750	51
15	PH380-4T-110G	220A	0-480VAC	110KW	620*380*310	486 to 750	54
16	PH380-4T-132G	250A	0-480VAC	132KW	620*380*310	486 to 750	55
17	PH380-4T-160G	310A	0-480VAC	160KW	817*500*348	486 to 750	94
18	PH380-4T-185G	340A	0-480VAC	185KW	817*500*348	486 to 750	96
19	PH380-4T-200G	380A	0-480VAC	200KW	817*500*348	486 to 750	98
20	PH380-4T-220G	415A	0-480VAC	220KW	817*500*348	486 to 750	98
21	PH380-4T-250G	470A	0-480VAC	250KW	1430*940*670	486 to 750	150

PH380-XX-L 2S series: Input 150-450V DC or 200 to 240V AC, VOC 350V DC							
1	PH380-2S-1P5G-L	7A	0-256VAC	1.5KW	298*165*201	260 to 375	3
2	PH380-2S-2P2G-L	10A	0-256VAC	2.2KW	298*165*201	260 to 375	3
3	PH380-2S-004G-L	16A	0-256VAC	4.0KW	310*205*225	260 to 375	4.5
PH380-XX-L 4T series : Input 350 to 800V/900V DC or 380 to 480V AC, VOC 620V DC							
1	PH380-4T-2P2G-L	5A	0-480VAC	2.2KW	298*165*201	486 to 750	3
2	PH380-4T-004G-L	10A	0-480VAC	4KW	298*165*201	486 to 750	3
3	PH380-4T-5P5G-L	13A	0-480VAC	5.5KW	310*205*225	486 to 750	4.5
4	PH380-4T-7P5G-L	17A	0-480VAC	7.5KW	310*205*225	486 to 750	4.5
PH380-XX-S 2S series: Input 150-450V DC or 200 to 240V AC, VOC 350V DC							
1	PH380-2S-1P5G-S	7A	0-256VAC	1.5KW	245**160*180	260 to 375	5
2	PH380-2S-2P2G-S	10A	0-256VAC	2.2KW	245**160*180	260 to 375	5
3	PH380-2S-004G-S	16A	0-256VAC	4.0KW	320*215*190	260 to 375	7.5
PH380-XX-S 4T series : Input 350 to 800V/900V DC or 380 to 480V AC, VOC 620V DC							
1	PH380-4T-2P2G-S	5A	0-480VAC	2.2KW	245**160*180	486 to 750	5
2	PH380-4T-004G-S	10A	0-480VAC	4KW	245**160*180	486 to 750	5
3	PH380-4T-5P5G-S	13A	0-480VAC	5.5KW	320*215*190	486 to 750	7.5
4	PH380-4T-7P5G-S	17A	0-480VAC	7.5KW	320*215*190	486 to 750	7.5
5	PH380-4T-011G-S	25A	0-480VAC	11KW	320*215*190	486 to 750	7.5
6	PH380-4T-015G-S	30A	0-480VAC	15KW	410*275*200	486 to 750	13
7	PH380-4T-018G-S	37A	0-480VAC	18KW	410*275*200	486 to 750	13
8	PH380-4T-022G-S	45A	0-480VAC	22KW	410*275*200	486 to 750	13

## Technical specification

Solar pump inverter mode only when PE-00=1 & 2	
Recommended MPPT voltage range	Vmp 131 to 350 VDC for 1S model (80V to 450VDC input, 110/220VAC output) Vmp 260 to 355VDC for 2S model ( 250V to 450VDC input, 0-240VAC output) Vmp 486 to 650 VDC for 4T model ( 350V to 800VDC input, 0- 480VAC output)
Recommended input Voc and Vmpp voltage	Voc 180(VDC), Vmpp 155(VDC) for 1S model or 110V AC pumps Voc 380(VDC), Vmpp 310(VDC) for 2S model or 220V AC pumps Voc 650(VDC), Vmpp 520(VDC) for 4T model or 380V AC pumps
Motor type	Adapt for permanent magnet synchronous motor(PMSM)and asynchronous motor pumps,submersible and surface pumps detc
Rated output voltage	Output under rated condition: 3 phase, 0~input voltage, inaccuracy<5%
Output frequency	0~maximum frequency 600Hz
MPPT efficiency	99.7%
Overload capacity	150% rated current for 60S, 180% rated current for 2S
Solar pump control special performance	MPPTandCVT (constant voltage tracking), timecontrol function,sandcleanfunction, dry run protection, lowfrequency stopprotection, minimum power input, motor maximum current protection, flow calculating, energy generated calculating and water tank level detected
Protection function	Phase loss protection, phase short circuit protection, ground to phase circuit protection, input and output short circuit protection. Stall protection, lightning protection
Protection degree	IP20 forPH380-XX-M/Lseries,IP54 for PH380-XX-S series.All Air force cooling
Running mode	MPPT or CVT
Enhanced version of AC drive	Design based on vector control AC drive, more specification please refer to PH100vector control drive operation manual
Certification	CE and IEC:(EN 61000-3-11:2000 )EN 62109-1/IEC 62109-1:2010EN 61800-5-1:2007+A1:2017EN IEC61800-3:2008(C3)/IEC 61800-3:2007(C2)
Storage temperature	-30 ~+60℃
Temperaturehumidity	-10 ~ + 50 ℃, derating above 40 ℃, maximum temperature 60 ℃ (no-loadoperation)5% to 95% RH (non-condensing)
Install place	altitude≤ 1000m,above 1000m down the rated amount, each increase of 100m down the ratedamount of 1%;no condensation, ice,rain, snow, hail; solar radiation below 700W/㎡, air pressure 70-106 KPa
Standard functions	PID control, speed track, power off restart, jump frequency, upper/lower frequency limit control, program operation, multi- speed, RS485, analog output, frequency impulse output

# Solar Pump System Diagram

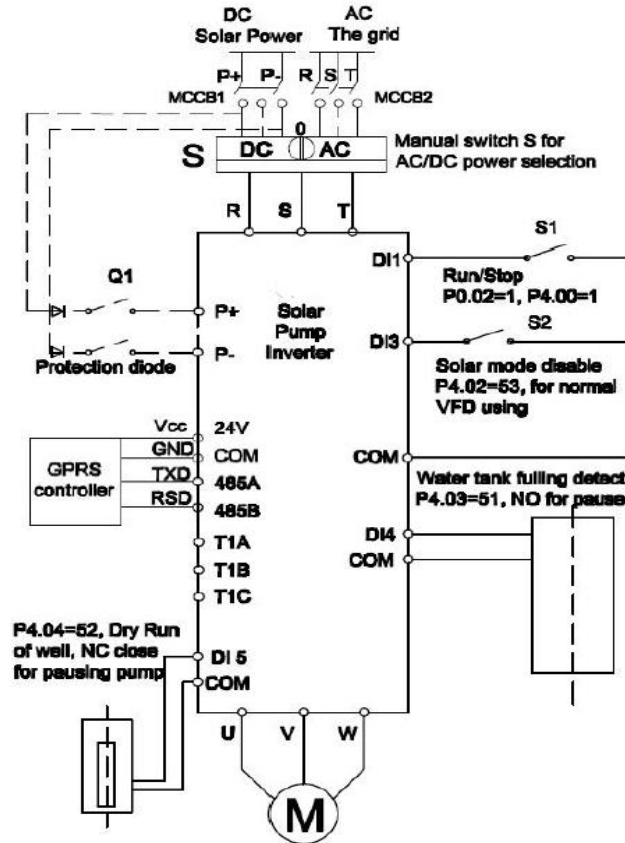

solar pump wiring 1, digital switch for water tank fulling

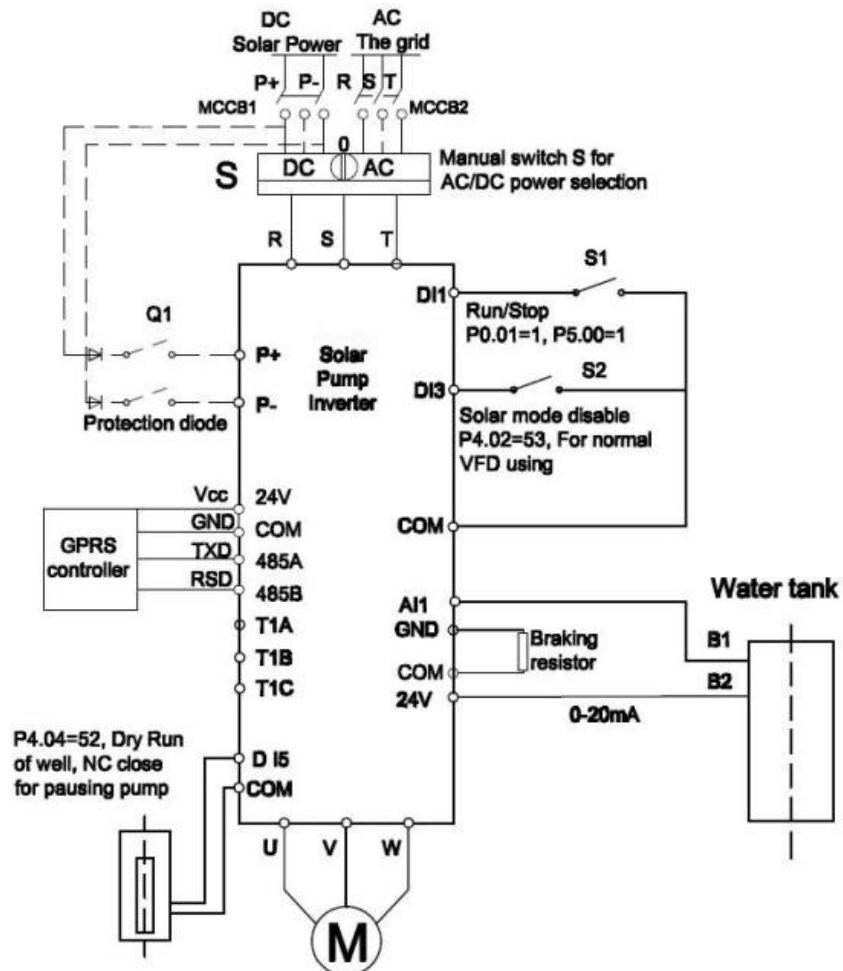

Wiring 2 for water tank fulling for analog type water sensor

## Optional

**LCD keypad-**  
2 line display  
Concise,persplicity



**Time card-**  
Set the working time,like  
start or stop time  
Normal battery inside



**AC output reactor-**  
Its connect between Solar pump inverter  
and and pump motor to suppress loop  
inrush current to protect the inverter and  
other devices. We suggest to use the  
reactor if the cable length above 100m



Look forward to more.....

# Applications



## Lahore, Pakistan

- Pump: 7.5kW / 3 phase 380V / 50Hz / 13.4A
- Inverter: PH380-4T-7P5G, 7.5KW, 17A
- Solar panel: POLY 360W/pc 24pcs total (12pcs in series with 2 parallel)
- Save 65% cost for the farmer



## Syria

- Pump: 11kW / 3 phase 380V / 50Hz / 22A /
- Inverter: PH380-4T-011G, 11KW, 25A
- Solar panel: POLY 270W/pc 48 pcs total (24 in series with 2 parallel)
- Save 65% cost for the farmer



## Egypt



We serve all around the world: [info@phaetondrive.com](mailto:info@phaetondrive.com)

